

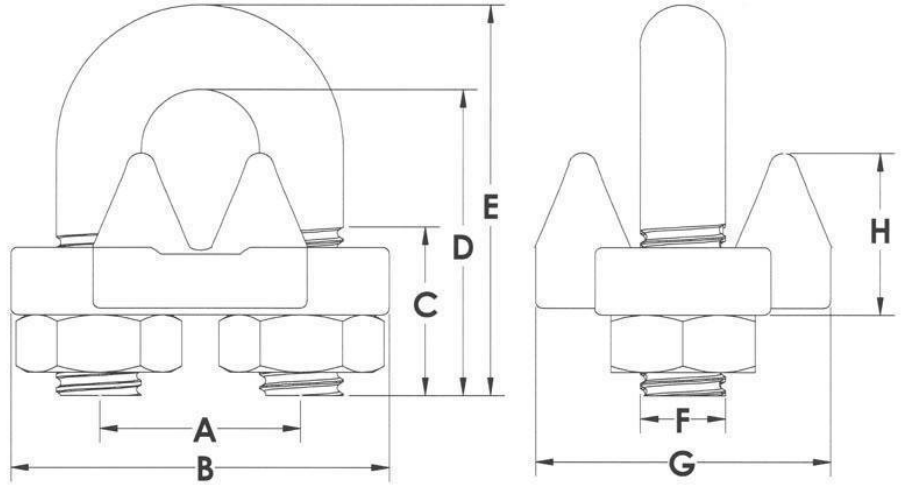

# Malleable Wire Rope Clips

Malleable Carbon Steel



## Specifications

- Process: Malleable
- Material: Carbon Steel
- Finish: Zinc Plated
- Origin: Import
- Specifications: Includes Regular Hex Nuts to Federal Specification FF-C-450 Type 1, Class

### ***Use Clips Properly For Maximum Efficiency:***

1. U-Bolt Should bear on dead end of rope
2. Use recommended number of clips, depending on safety Requirement.
3. Spacing between clips should be 6 times the rope diameter.
4. Nuts should be re-tightened after Initial Load.

Part Number	Rope Size	Inside Length Of U-Bolt	Min Number of Clips for Max. Strength	Weight
20900	1/16	23/32	2-4	0.018
20905	1/8	23/32	2-4	0.030
20910	3/16	15/16	2-4	0.060
20915	1/4	1 1/32	2-4	0.100
20920	5/16	1 5/16	2-4	0.122
20925	3/8	1 1/2	2-4	0.212
20930	7/16	1 7/8	3-4	0.270
20935	1/2	1 7/8	3-4	0.362
20940	9/16	2 1/4	3-4	0.464
20945	5/8	2 3/8	3-4	0.476
20950	3/4	2 3/4	4-5	0.762
20955	7/8	3 1/8	4-5	1.294
20960	1	3 1/2	4-5	1.328
20965	1-1/8	3 7/8	6-8	2.514
20970	1-1/4	4 1/4	6-8	3.052